

PL90 PL90FF

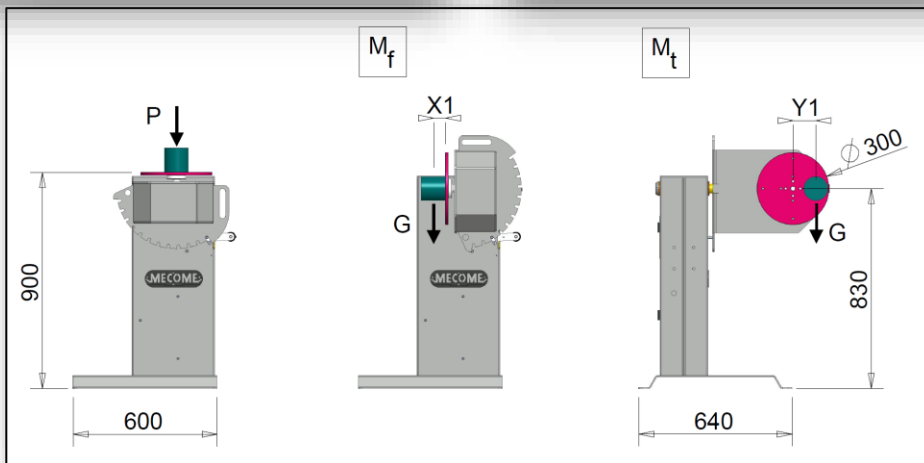
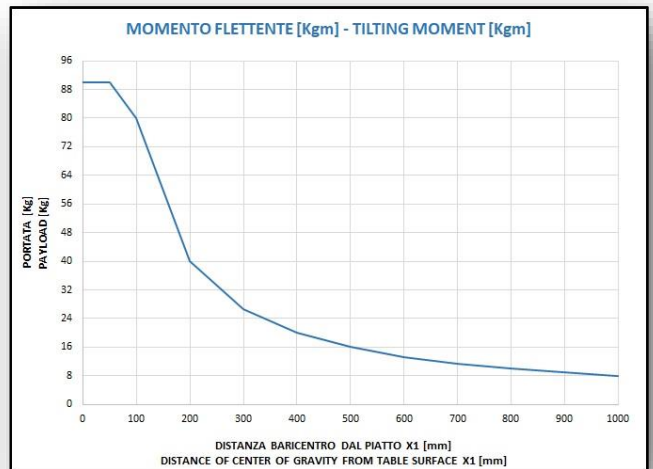
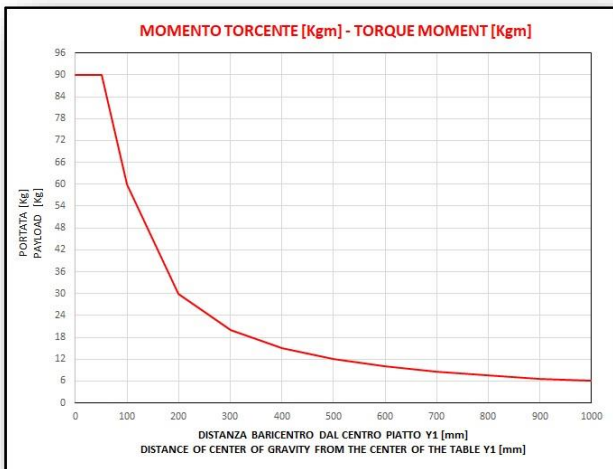

MODELLO (MODEL)	PORTATA (PAYLOAD) Kg	VELOCITA' ROTAZIONE (ROTATION SPEED) RPM	M_t Kgm	M_f kgm	INCLINAZIONE (TILTING)	VOLT
PL 90	90	0,7 - 7	6	8	MANUALE (MANUAL)	230
PL90FF	90	0,7 - 7	6	8	MANUALE (MANUAL)	230

MECOME S.r.l.

Via Fornace Ila Strada, 22 Fraz. Arsego
35010 San Giorgio delle Pertiche (PD), Italy

info@mecome.it www.mecome.it

C.F. e P.IVA IT 01145830285 Reg. Impr. PD n. 01145830285 - R.E.A. PD n.

188156 - CAP. Soc. € 100000,00 i.v. Tel: +39 049 9330425 Fax +39 049 9330434



PL90 PL90FF



CARATTERISTICHE - CHARACTERISTICS	PL90	PL90FF
INCLINAZIONE MANUALE - <i>MANUAL TILTING</i>	●	●
FINECORSO 360° - <i>360° STROKE-END</i>	●	●
SCHERMATURA PER ALTA FREQUENZA ELETTRONICA - <i>ELECTRONIC HIGH FREQUENCY PROTECTION</i>	●	●
INVERSIONE DI MARCIA - <i>INVERSION SENSE OF ROTATION</i>	●	●
MASSA ROTANTE INCORPORATA - <i>INCORPORATED ROTATING MASS</i>	●	●
SELETTORE PER COMANDO ROTAZIONE (IMPULSI/AUTOMANTENIMENTO) - <i>ROTATION CONTROL SELECTOR (I/A)</i>	●	●
PEDALE SINGOLO PER MARCIA-ARRESTO - <i>START-STOP PEDAL (1PEDAL)</i>	●	●
RITARDO PARTENZA PIATTO - <i>PLATE START DELAY</i>	—	●
SORMONTO ELETTRONICO E RITORNO A ZERO - <i>ELECTRONIC OVERLAP AND RETURN TO ZERO POSITION</i>	—	●
COMANDO PER 2 GENERATORI - <i>2 WELDING POWER SOURCES ENABLING CONTROL</i>	—	●
GESTIONE EVANESCENZA - <i>FADING CONTROL</i>	—	●

ACCESSORI - ACCESSORIES	PL90	PL90FF
VARIAZIONE GIRI - <i>DIFFERENT rpm</i> **	○	○
BPR40 BRACCIO PNEUMATICO PORTA TORCIA REGOLABILE- <i>ADJUSTABLE TORCH HOLDER PNEUMATIC ARM</i>	○ ¹	○
BPR40 BRACCIO MECCANICO PORTA TORCIA - <i>ADJUSTABLE TORCH HOLDER MECHANICAL ARM</i>	○	○
SCHEDA FULL FUNCTION - <i>FULL FUNCTION BOARD</i>	○	●
PIATTO ASOLATO - <i>PLATE WITH SLOTS</i> **	○	○
GIUNTO ROTANTE - <i>ROTATING JOINT</i> **	○	○
PEDALE POTENZIOMETRICO - <i>POTENTIOMETRIC PEDAL</i> **	○	—

● **Serie / Series** ○ **Optional / Options** — **Non disponibile / Not available**

** **Richiesta in fase d'ordine - valid only if ordered with the machine**

¹ **Disponibile previo acquisto scheda Full Fuction - Available subject to previous purchase of Full Fuction board**

MECOME S.r.l.

Via Fornace Ila Strada, 22 Fraz. Arsego
35010 San Giorgio delle Pertiche (PD), Italy

info@mecome.it www.mecome.it

C.F. e P.IVA IT 01145830285 Reg. Impr. PD n. 01145830285 – R.E.A. PD n.

188156 – CAP. Soc. € 100000,00 i.v. Tel: +39 049 9330425 Fax +39 049 9330434

